

DESIGN APTITUDE TEST 2019
POSTGRADUATE

Total No. of Pages:25

Permitted Time: 3 Hours

TOTAL MARKS - 100

Kindly read the instructions carefully given on the next page before attempting the questions.

To be filled by the student.

CANDIDATE ID :

CANDIDATE NAME :

TEST CENTRE :

<input type="checkbox"/> AHMEDABAD	<input type="checkbox"/> BENGALURU	<input type="checkbox"/> BHOPAL	<input type="checkbox"/> CHANDIGARH	<input type="checkbox"/> CHENNAI
<input type="checkbox"/> DELHI	<input type="checkbox"/> GUWAHATI	<input type="checkbox"/> JAIPUR	<input type="checkbox"/> HYDERABAD	<input type="checkbox"/> KOLKATA
<input type="checkbox"/> LUCKNOW	<input type="checkbox"/> MUMBAI	<input type="checkbox"/> NAGPUR	<input type="checkbox"/> PATNA	<input type="checkbox"/> PUNE
<input type="checkbox"/> DEHRADUN	<input type="checkbox"/> INDORE	<input type="checkbox"/> KOCHI	<input type="checkbox"/> RAIPUR	<input type="checkbox"/> NASHIK
<input type="checkbox"/> VARANASI	<input type="checkbox"/> THIRUVANANTHAPURAM	<input type="checkbox"/> RANCHI	<input type="checkbox"/> BHUBANESWAR	

*Please read the instructions on the next page.

DAT Paper is sealed. Do not break/open until asked to do so.

INVIGILATOR'S SIGNATURE

FOR OFFICIAL USE ONLY	
Marks	Examiner's signature

INSTRUCTIONS TO THE CANDIDATES:

You will be informed when to start the examination by the invigilator.

Read these instructions carefully before attempting the questions.

1. Write your Name, Candidate ID number and the Examination Center in the space provided on the cover page of this answer book as well as on all the pages of answer book.
 - a. No distinctive mark of any sort is to be put anywhere in the answer book.
 - b. Violation of these instructions or adoption of malpractice in examination hall will lead to disqualification.
 - c. Please make sure you have signed the registration sheet provided by the invigilator **to mark your presence.**
 - d. Make sure that you have written your Candidate ID Number and signed on all pages in the space provided.
2. Write your answers ONLY IN ENGLISH.
3. Candidates shall not be allowed to leave the examination hall till after completion of at least one and half hours (90 Minutes) from the commencement of the examination.
4. Postgraduate DAT Paper consists of 18 Questions.
 - a. The Question paper contains two parts, PART A (50 marks – Thirteen questions) and PART B (50 marks – five questions).
5. All questions are compulsory.
6. Write or draw your answers only in the space provided for respective questions.
 - a. Space has been provided against each question for a FINAL ANSWER.
 - b. Extra rough work sheets and backside of the paper to be used for ROUGH WORK ONLY.
- 7. DO NOT REMOVE ANY SHEET from this answer book.**
8. Before leaving the examination hall, kindly submit this question-cum-answer paper to the invigilator.
9. Use of stationery: Use Ball Pen (Blue Ink), Pencils (B, 2B, 4B, 8B), colour pencil set & Eraser only.
10. DAT Paper will be collected at the end of the test / examination.
11. Maximum Duration for the completion of the test is 180 minutes (3 hrs.).

PART – A

No. of Questions	Marks of each question	Total marks	Total marks 50
1 - 5	2	10	
6 - 13	5	40	

QUESTION NO. 1

02 MARKS

Who is lead designer of game PUBG?

(Tick the correct answer below)

- A. Brendan Greene
- B. Hideo Kojima.
- C. Gabe Newel.
- D. Toby Gard

QUESTION NO. 2

02 MARKS

“Pininfarina” the Italian car design firm and coach builder, was acquired by which Indian company

(Tick the correct answer below)

- A. Tata Motors.
- B. Reliance Motors.
- C. Hyundai motors.
- D. Mahindra& Mahindra.

QUESTION NO. 3

02 MARKS

If A=4, B=3, C=4, D=2

$A+B-C+A+B+C+A+B+D+C+A+A+B+C+D-D+C-A+B-D+A-B+C-A+A-B+B+D-A-C-B-A+A-B+C-A+B-D+A+C+D-B+C-B+A-D-B+A-B+A-A+D+B+C+C+A-D-C-B=?$

Ans.

QUESTION NO.4

02 MARKS

Who is the sculptor of the “OSCAR STATUETTE”?

- A. George Stanley
- B. Emil Jannings
- C. Cedric Gibbons
- D. Elizabeth Dragan

QUESTION NO. 5

02 MARKS

Who founded the Bauhaus in Weimar, Germany?

(Tick the correct answer below)

- A. IngeAicher-Scholl
- B. Walter Gropius
- C. Otl Aicher
- D. Max Bill

ABCDEFGHIJKLMN
 OPQRSTUVWXYZÀ
 ÅÉÎÏØÛabcdefghijklmnop
 mnopqrstuvwxyzàåéîõ
 ø&1234567890(\$£€.,!?)

Which typeface is this? Recognize the Typeface above. And tick in the correct (name) answer below.

- A. Bodoni
- B. Chaparral
- C. Didot
- D. Rockwell

Write the letter “R” in other three typefaces mentioned above, except the ticked (right answer selected above) one below.

--	--	--

QUESTION NO. 7

05 MARKS

State Bank of India logo is design by (Tick the correct answer below)

- A. Sudarshan Dheer
- B. Tarun Deep Girdhar
- C. Mahendra Patel
- D. Shekhar Kamat

Draw the Logo of State Bank of India and Syndicate bank below (Pencil colour rendering)

State Bank of India Logo:	Syndicate Bank logo:
---------------------------	----------------------

QUESTION NO. 8

05 MARKS

Lamborghini logo stands for which zodiacal sign (Tick the correct answer below)

- A. Taurus
- B. Aries
- C. Libra
- D. Leo

Draw the same logo below (color rendering)

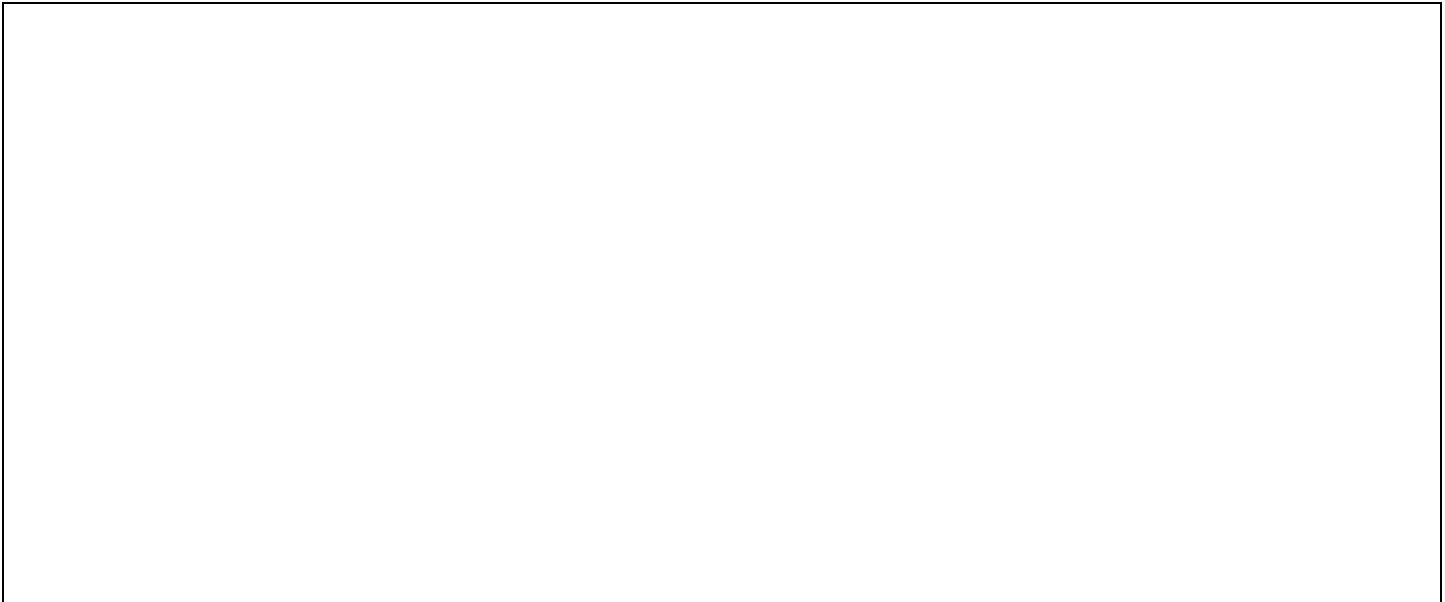

QUESTION NO. 9

05 MARKS

What number is missing? (Tick the correct answer below)

1. 38 (19/24) 96
2. 64 (32/17) 68
3. 48 (___/___) 56

- A. 24/14
- B. 24/13
- C. 24/15
- D. 24/17

Take the selected option and create a two dimensional composition (of the numbers) to depict 'Balance' below
(Pencil Color Rendering)



QUESTION NO. 10

05 MARKS

Name famous six luxury wrist watch brands of the world.

Draw (color rendered) logos of those six brands you mentioned.

Brand 1:	Brand 2:	Brand 3:
Brand 4:	Brand 5:	Brand 6:

How many different types of shapes are there in the above chart? Count the numbers of each type of shape in the above chart.

Now draw each type of shape and also mention the number of each type of shape in the chart below.

Shape	Shape	Shape	Shape	Shape	Shape	Shape	Shape	Shape
Number	Number	Number	Number	Number	Number	Number	Number	Number
Shape	Shape	Shape	Shape	Shape	Shape	Shape	Shape	Shape
Number	Number	Number	Number	Number	Number	Number	Number	Number

QUESTION NO. 12

05 MARKS

Take any two elements from given pictures below and design your own Bed room. (consisting of these objects wall paper, bed sheet, pillow, curtains, blankets)



A large empty rectangular box provided for the student to design their own bedroom based on the provided botanical elements.

QUESTION NO. 13

05 MARKS

Draw (Pencil Color rendering) four different sitting objects below...

(Two for luxury interior design, one for retail interior design, one for open garden)

Sitting object 1:	Sitting object 2:
Sitting object 3:	Sitting object 4:

PART – B

No. of Questions	Marks of each question	Total marks	Total marks 50
14 - 18	10	50	

QUESTION NO. 14

10 MARKS

Create/assume a style board of a luxurious interior space of your choice.
Create three drawings (with pencil colour rendering) of that space from –

1. Human eye level
2. Worm’s eye view [view from below]
3. Bird’s eye view [view from the top]

Style Board:

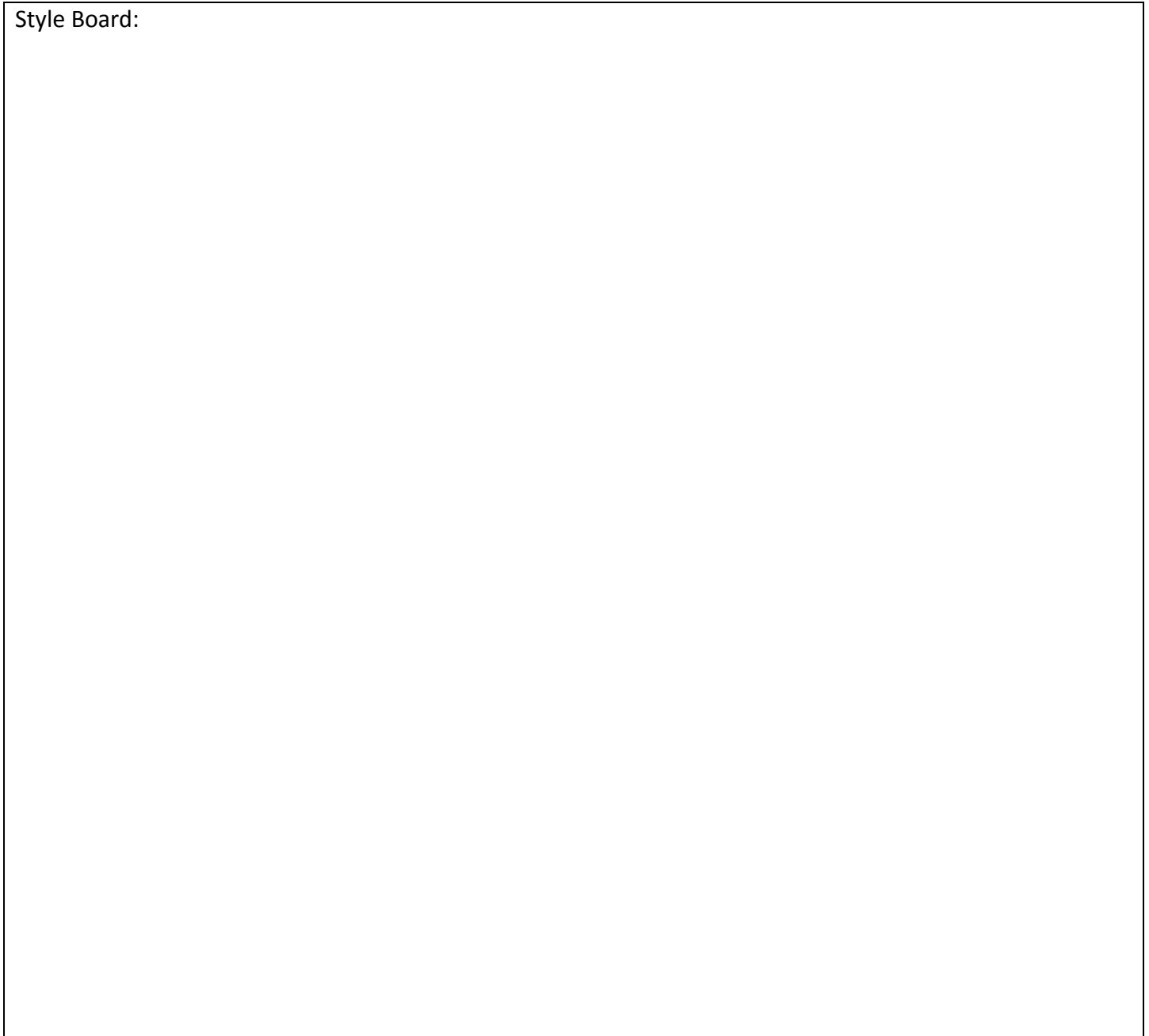

Drawing from Human eye level:

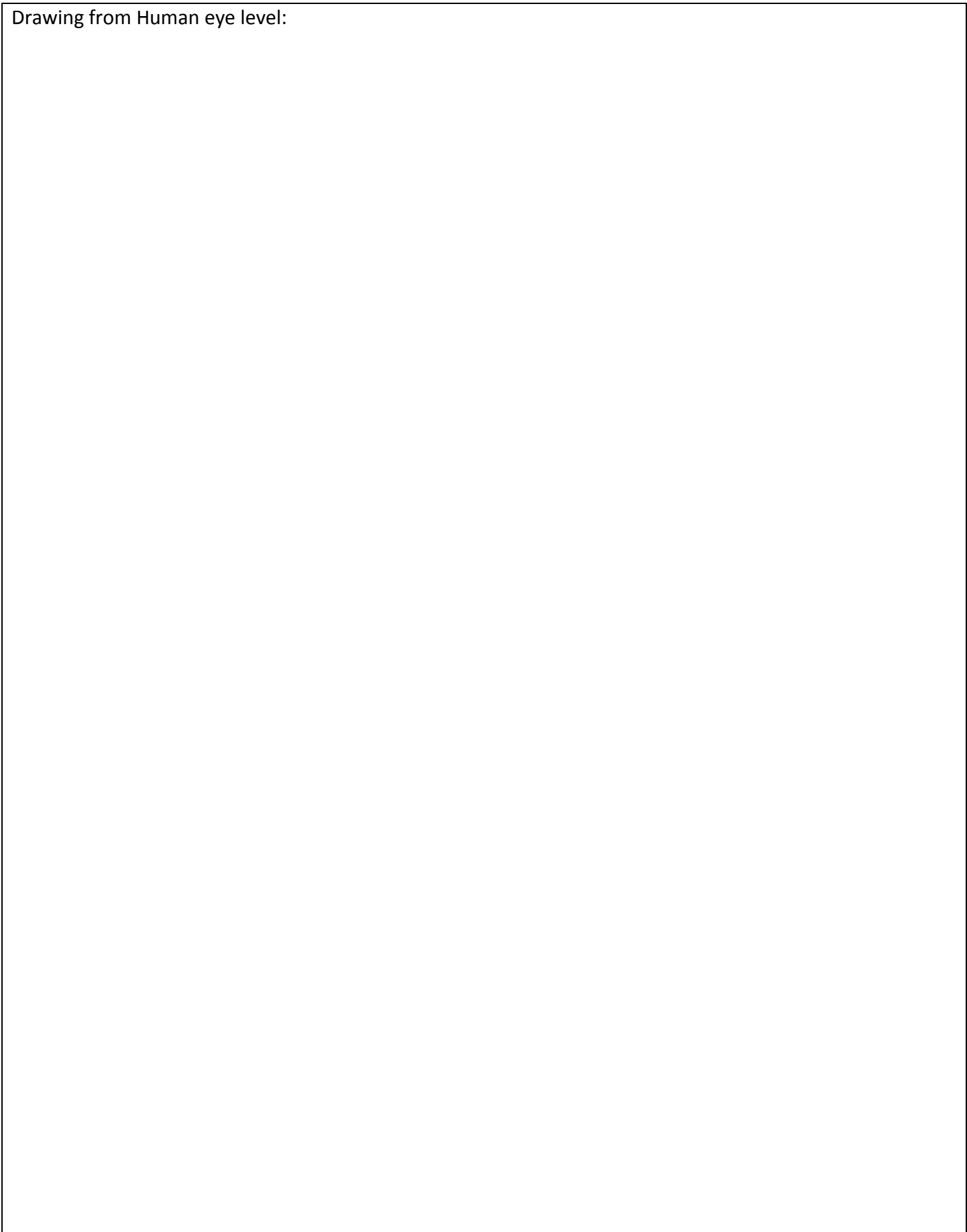

Drawing from Worm's eye view [view from below]:

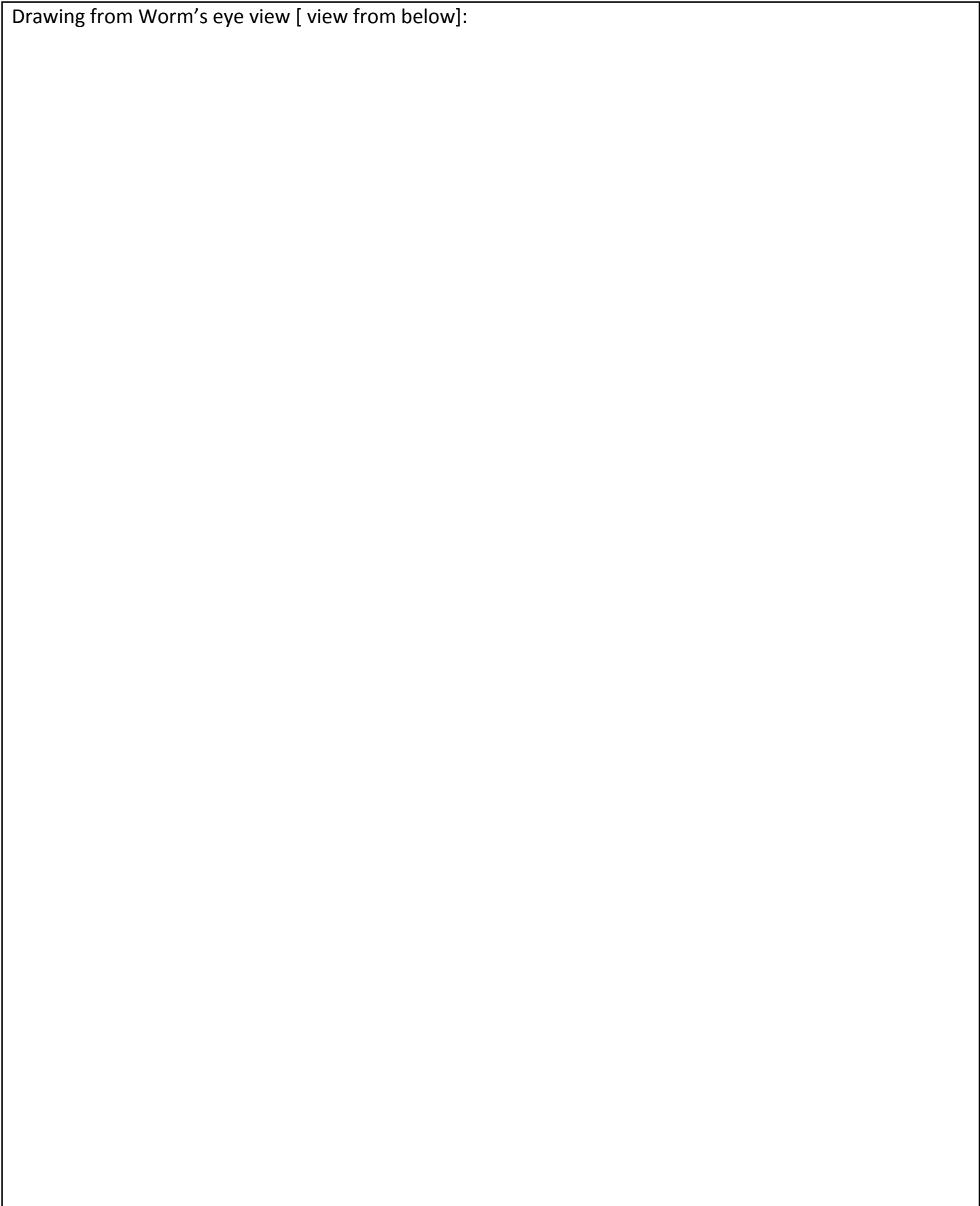

Drawing from Bird's eye view [view from the top]:

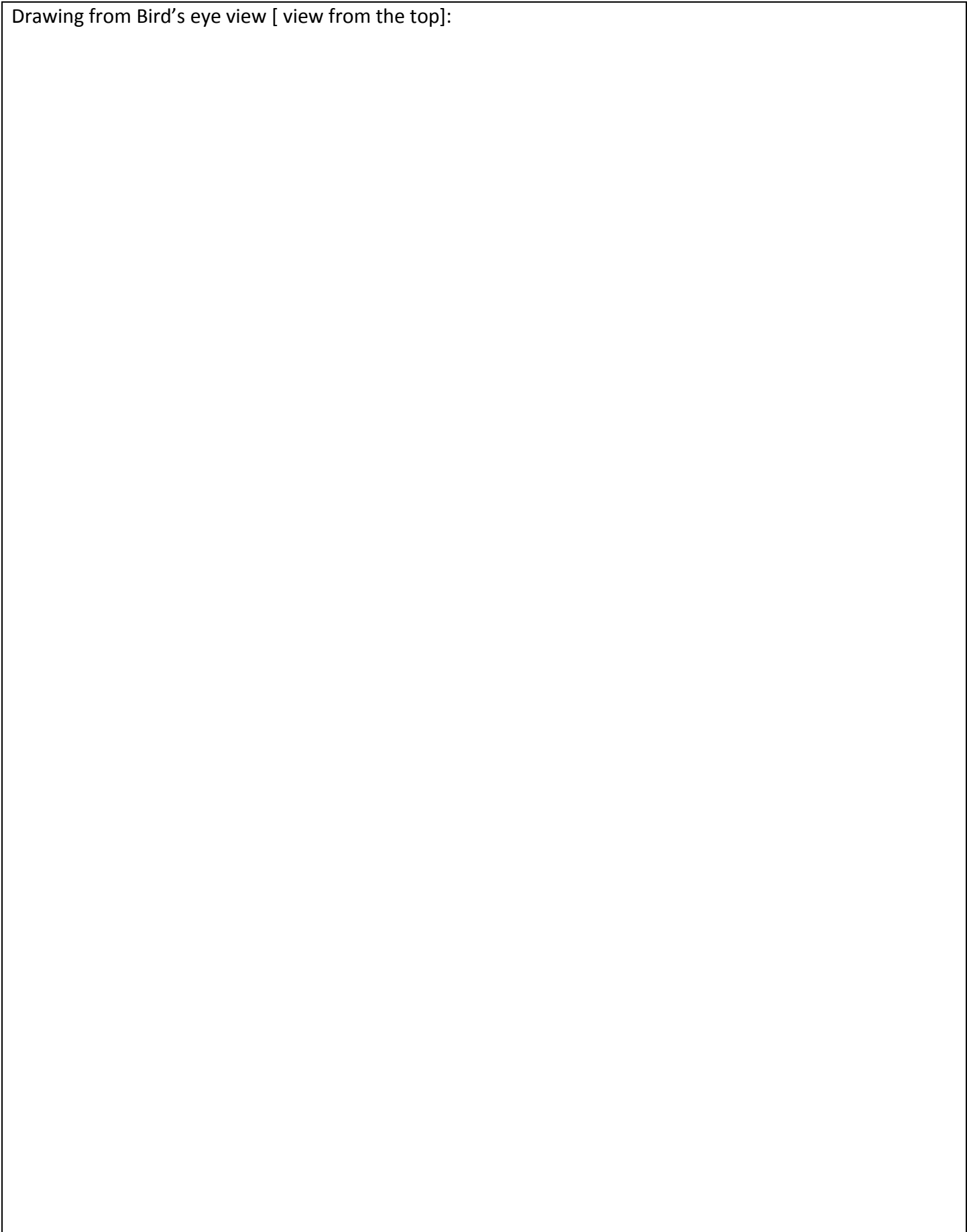

QUESTION NO. 15

10 MARKS

a) Define any one textile craft of India from the list below –

- *Kantha work,*
- *Banarasi brocade,*
- *Bandhni,*
- *Kalamkari,*
- *Ikat,*
- *Zardozi work*

b) Draw and create a contemporary dress form for men, using the same textile craft you have selected.



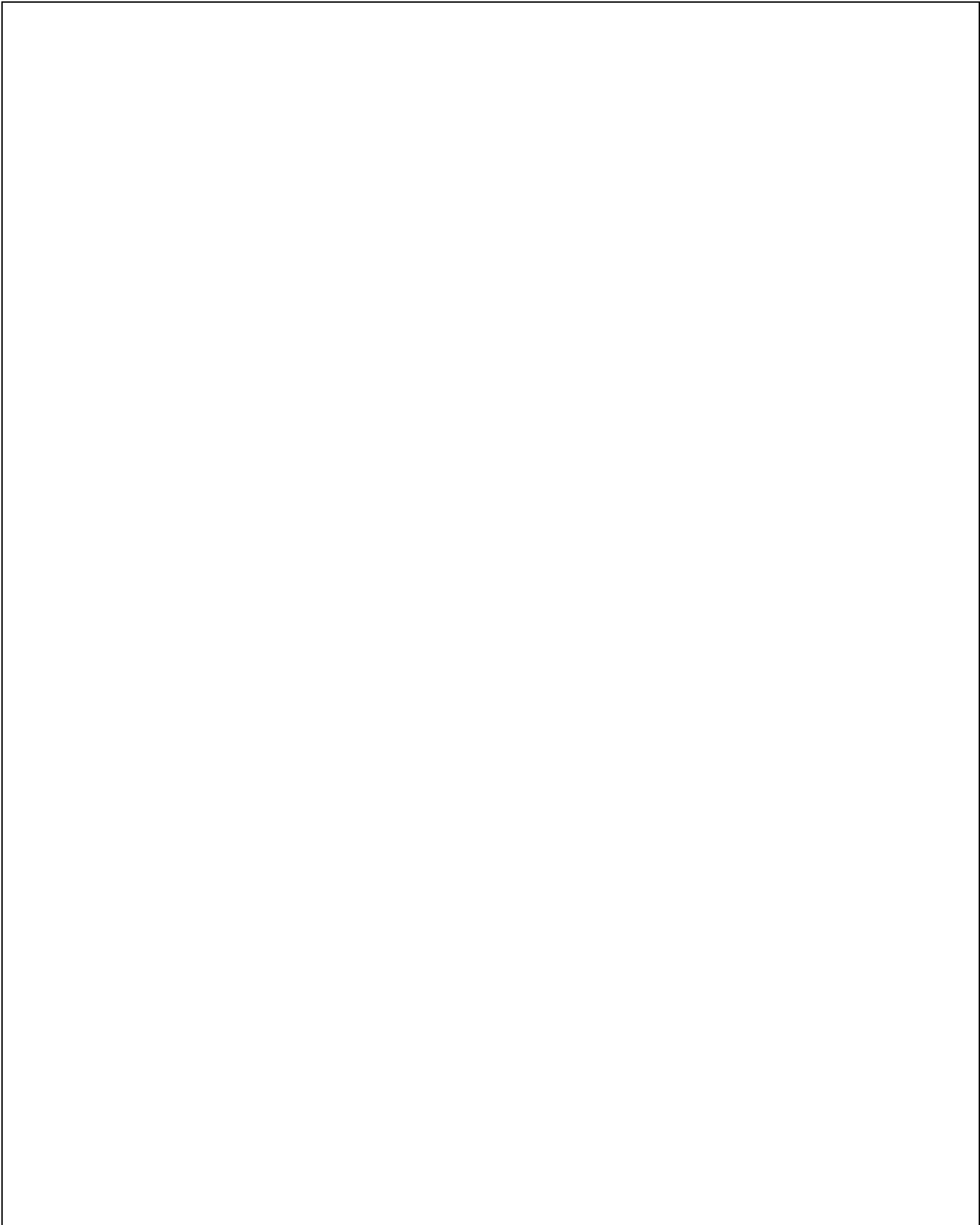

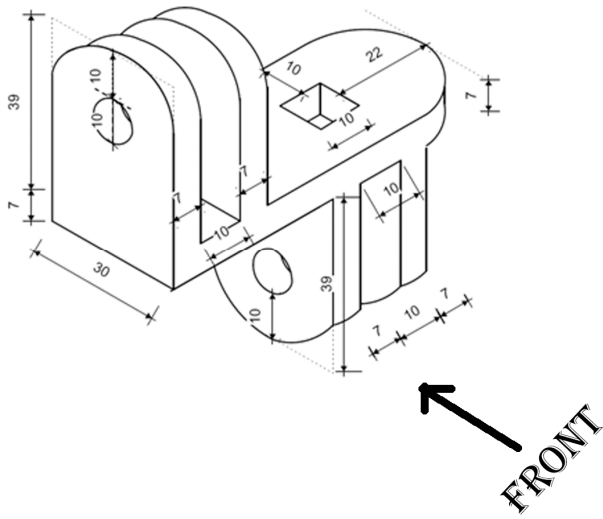

Draw the Plan, Front elevation, right and Left side elevations of the given object shown above, according to the measurement given (show hidden lines as dotted). All dimensions are in mm only.

Plan	Front elevation
------	-----------------

Right side elevation

Left side elevation

QUESTION NO. 17

10 MARKS

Below are some images of products that were used across the world in different time period, are placed in a random order. Name, rearrange and write down the correct sequence (Classic to Modern).



<u>A</u>	<u>B</u>	<u>C</u>	<u>D</u>	<u>E</u>
----------	----------	----------	----------	----------

<u>Name</u>	<u>A-</u>	<u>B-</u>	<u>C-</u>	<u>D-</u>	<u>E-</u>
<u>Chronology</u>					

Choose one object from the above and create a packaging design (pencil Color rendering). of the product in detail, with dimensions.

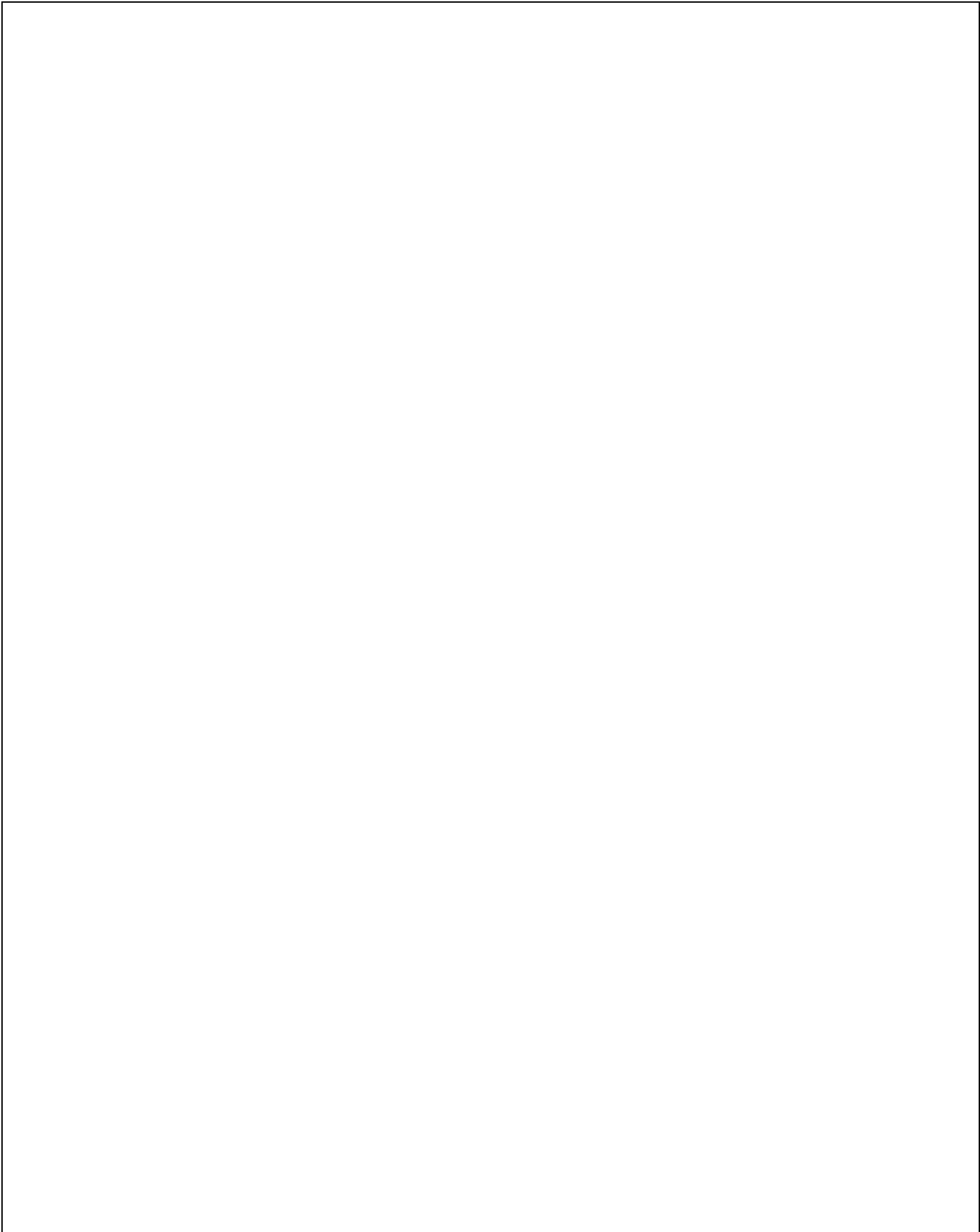

QUESTION NO. 18

10 MARKS

“Organic cotton is grown using methods and materials that have a low impact on the environment. Organic production systems replenish and maintain soil fertility, reduce the use of toxic and persistent pesticides and fertilizers, and build biologically diverse agriculture.”

How would you promote Organic Cotton worldwide? Give **three** concepts (below). Represent one concept graphically.

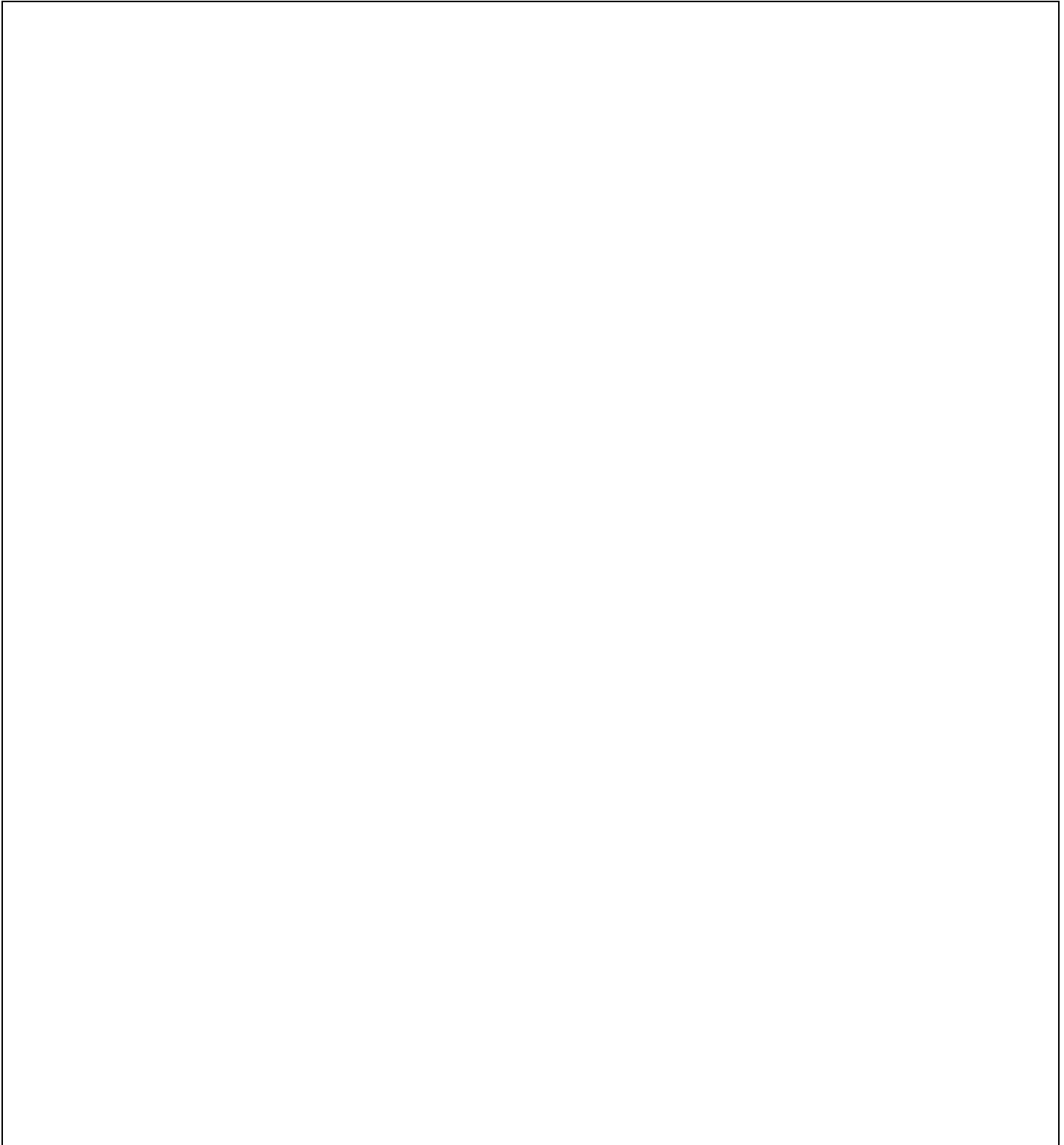

ROUGH WORK

ROUGH WORK

ROUGH WORK